



Silicon Diodes - Testing and Identifying

The most obvious sign of a rectification problem in a plating rectifier, is a loss of D.C. output amperage. Operators may notice that they have to turn the output control up to a higher setting to pull the same amount of current with the same load. Depending on the size of the rectifier, operators may have to continue turning the output control of diodes and how heavy you load your rectifier, operators may have to continue turning the output control setting higher and higher until either the overload protection, or damage, turns the rectifier off.

The following report was written to try to help explain testing, identifying, and purchasing replacement silicon diodes to someone who has little, or no electrical background concerning testing standard D.C. Plating Rectifiers.

Silicon Diodes are best tested under load while the rectifier is on. This is easily accomplished with a hand held A.C. Clamp-On "Tong Tester" type meter. Standard models usually include A.C. and D.C. voltage ranges. Both the A.C. and the D.C. amperage type meters may be used, although the A.C types are more common.

If you are using an A.C. type ammeter, multiply the A.C. amperage read, by 1.37 to obtain a true D.C. amperage. Finding the true D.C. amperage reading is really not necessary, because we are most interested in finding that all the diodes are conducting current and balanced. Balanced means that each diode is carrying approximately the same current.

For experience and practice, I would recommend purchasing a Clamp-On Tong Tester and take a few tests with a rectifier that is working correctly. The rectifier must be on and have a slight load. An open diode, which is usually the case, will show up very easily. It will not draw any current. Shorted diodes will draw much more current than any of the other diodes. Shorted diodes normally blow the diode fuses or burn their pigtails off. Shorted, or open diodes can both damage the Power Transformer.

For testing silicon diodes in a rectifier that you suspect trouble, first adjust your load to less than 50% of its rated output current. Do not full load the rectifier. This could cause more diodes to blow, or be damaged.

Always begin testing with the ammeter set on its highest range or scale. You can always lower the range. Pegging the meter, or reading more current on the ammeter scale than it is set at, can damage the meter. Begin testing one diode at a time. It is not necessary to clamp the meter right over the diode itself. The test can be made anywhere along



Figure 1

the diode cable from the diode pigtail to the power transformer, either before, or after diode fuses, if they are present. If diode fuses are used, be sure to check that the fuses are good before replacing any diodes. See Figure # 1.

If a diode fuse is found blown open, I would suspect the diode to be shorted. Take an ohmmeter, or continuity test before replacing the diode fuse and applying power.

The main advantage of purchasing a Tong Testing type meter is that tests can be made quickly and simply, without disconnecting any wires. The meter is also useful for other tests throughout the rectifier and other electrical equipment. Normal price for an adequate meter is from \$50.00 to \$125.00.

One point to remember is that the A.C. line power is on and extreme caution should be taken. Also watch out for fan motor blades.

The next best method of testing silicon diodes is to use an ohmmeter, or continuity tester. See Figure #2.

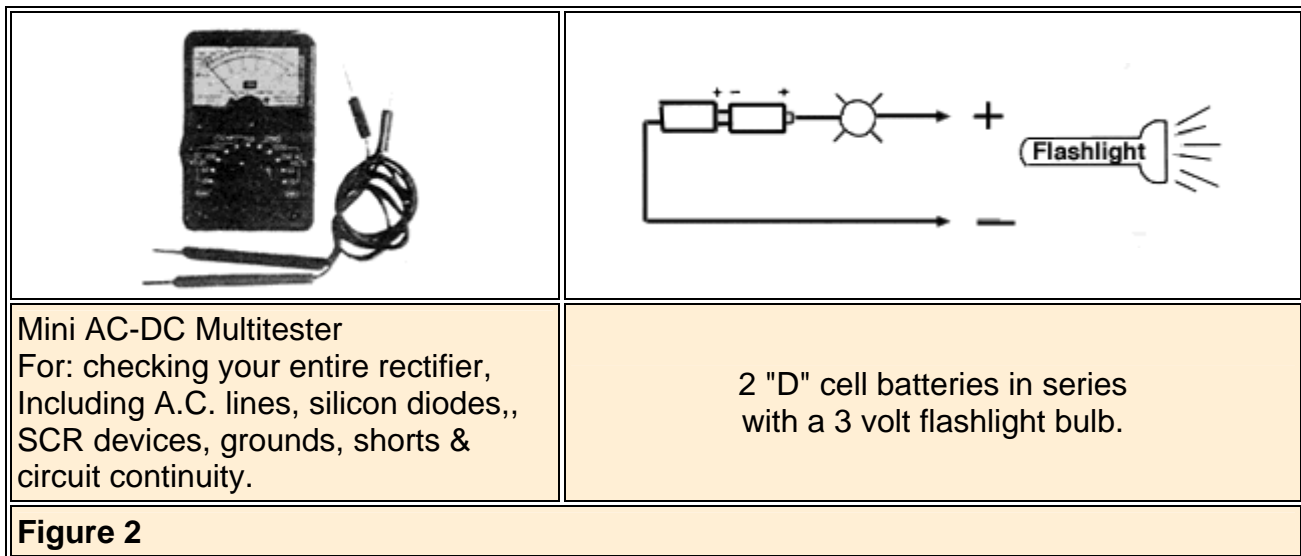

With this test, disconnect the A.C. power to the rectifier. Here we are most interested that the silicon diode conducts in one direction with respect to positive and negative, and does not conduct in the other direction when the leads are reversed.

When testing silicon diodes in the rectifier with an ohmmeter, one side of the diodes has to be disconnected. It is usually easier to unbolt the pigtail side of the diodes, because of the smaller size bolt.

We will assume, for this explanation, that the diodes for this test are forward polarity. If you are in question, read the later paragraph in identifying silicon diodes. Set your ohmmeter (if meter

is used) on the X1 scale. Short the meter leads together and zero your meter. You should have continuity. Connect the black negative lead to the diode base or stud. In common rectifier circuits, the base or stud of the diode is bolted to a heat sink. You can clip your meter to the heat sink for taking your readings.

Connect the red or positive test lead to the diode pigtail. If the diode is good, your meter will read a low resistance of approximately "0" to 100 Ohms. Now swap the leads, putting the red lead on the diode base and the black lead on the diode pigtail. You should find a high resistance reading in the range of 100 to 50,000 Ohms. This is variable in diodes, depending on the manufacturer. A 100 to 1 ratio is good. If both readings are ZERO, then the diode should be considered shorted and replaced. If both readings are HIGH, then the diode is open and should also be replaced.

Move along to the remaining diodes in the rectifier. It is a good idea to have a piece of white chalk, or tape, to mark bad diodes for identification.

A simple continuity tester, shown in Figure #2, will show that the diode conducts in one direction and not in the other. This test is very simple and inexpensive, but the validity of the test is high. Of course, a silicon diode can test o.k. on a bench, but short circuit under a load. It is still best to use a Clamp-On Tong Tester, for testing the diodes under load.

In some cases where servicing is difficult, diodes sometimes have to be totally removed, and tested outside the rectifier. Disconnect the A.C. power before entering the rectifier. Run through the same process using an ohmmeter or a continuity tester.

If no test instruments are available for testing diodes, a good point to remember is that a good diode passing current will heat up. A diode not pulling current, or open diode, will be cool. Pull the A.C. line switch before entering your rectifier to feel the diodes. If you find an extremely hot diode, or if the braided pigtail had discolored, I would suspect that diode of being shorted.

Identifying Silicon Diodes

For various engineering reasons, different rectifier manufacturers will use both forward and reverse polarity silicon diodes in the same machine. See Figure #3. Common circuits normally have the reverse silicon diodes mounted by their stud or base on a heat sink directly mounted to the negative bus bar. The forward polarity diodes are mounted by their stud or base on the positive heat sinks, or bus bars. Forward and Reverse diodes are identified by their number or diode symbol, which is an arrow with a perpendicular line across the arrow point. If the arrow points towards the base or stud, the diode is forward polarity. If the arrow points towards the pigtail, the diode is reverse. See Figure #3.

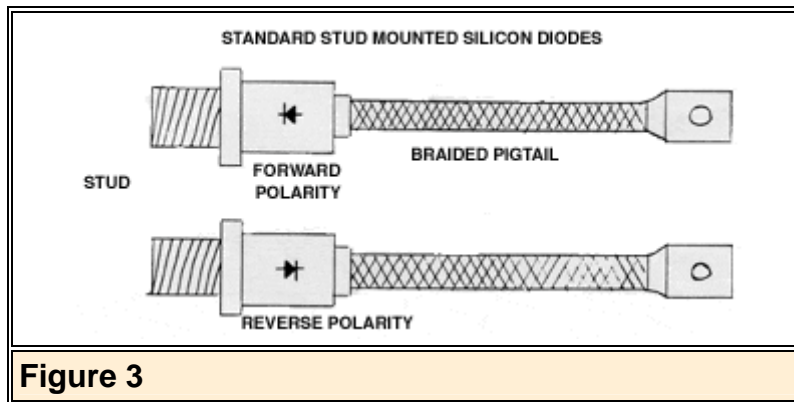

Good diodes can also be identified using an ohmmeter. Touch the positive red lead to the pigtail and touch the negative black lead to the base. You will have a continuity reading, if the diode is forward polarity. Obtaining a reading with the meter leads reversed, indicates a reverse polarity diode.

A shorted or open diode can not be identified by either ohmmeter, or a continuity tester. It had to be identified by either the arrow direction diode number, or the type of circuit.

Replacement

It is not always necessary to purchase replacement diodes from the original equipment manufacturer. The three main concerns are (1) Physical size; you can generally judge the current rating of a diode by its stud, or base size. You also want the stud to fit into the hole. (2) Amperage rating; you have to at least meet the current rating of the original manufacturers silicon diode. Getting a larger amperage rating would not hurt at all, and (3) Voltage or P.R.V. (peak reverse voltage) rating. This is the amount of reverse voltage the silicon diode can handle without damage to itself in the blocking direction. Always be sure the voltage rating of the new diode is four times the output voltage of your rectifier. This usually is not a problem at all with low voltage plating rectifiers.

Going to a higher peak reverse voltage rated diode is all right when purchasing. It gives you added protection against voltage spikes.

This article concentrated on stud mounted silicon diodes, although the procedure is basically the same for "Hockey Puck" types. If you have questions on hockey puck silicon diodes or any other types of rectification, please feel free to call us.