

DARRAH'S

Rectifier Inverter Assembly

Air Cooled



- **H Bridge IGBT Inverter**
100 Amp through 400 Amp IGBT's in either 1200 or 1700 Volt
- **Optional IGBT Firing Circuit**
Compatible with Semikron Skiip Package
- **Diode or SCR Front End Rectifier**
With or Without SCR Firing Board
- **Input: 240-480 Volt, 3 Phase, 50/60 Hertz**
- **D.C. Filter Capacitors**
10,200 MFD, 900 Volt
- **IGBT Snubber Capacitors**
- **Forced Air 115/220 Volt Fans**
- **Other Ratings Available**

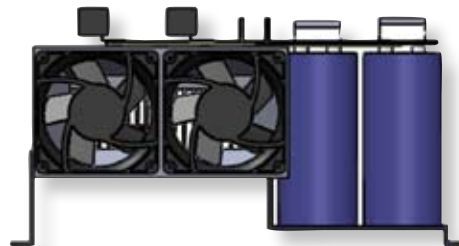
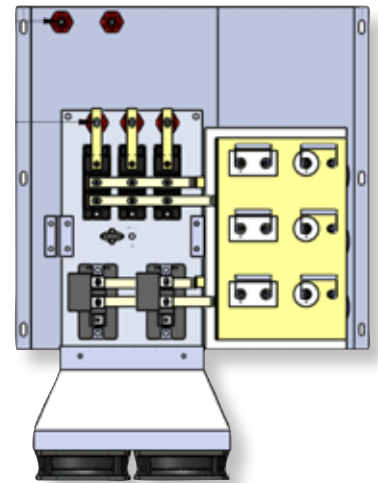
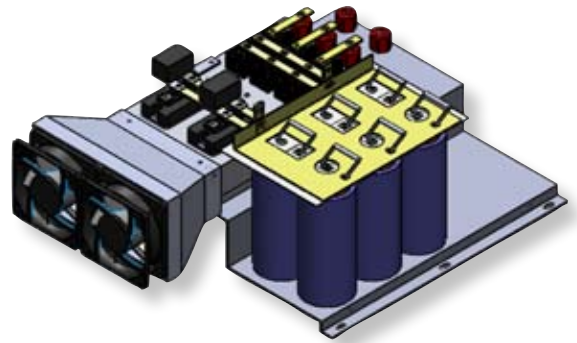

ISO 9001:2000 Certified

DARRAH ELECTRIC COMPANY

5914 MERRILL AVENUE • CLEVELAND, OHIO 44102

Toll Free 800-621-0014 Cleveland 216-631-0912 Fax 216-631-0440 E-mail decdarrah@earthlink.net

www.darrahelectric.com